

Article I. AndyMark TB3 Assembly Instructions

October 2011



Parts needed to make one (1) TB3 Box:

Tools needed:

Component	Qty	Part #
1/2" id flanged, shielded ball bearing (FR8ZZ)	1	am-0030
3/8" id bearing, flange, shielded (FR6ZZ)	5	am-0028
TB3 Motor Plate	1	am-0978
TB3 Shaft Plate	1	am-0979
Toughbox Extrusion Housing Enclosure	1	am-0260
Toughbox Large Cluster Gear	1	am-0149
Toughbox Large Output Gear	1	am-0150
Toughbox Small Cluster Gear	2	am-0151
Toughbox Small Hex Shaft	2	am-0152
Toughbox Output Shaft	1	am-0153
60t 32dp Output Gear	1	am-0927
15 tooth, 32dp Sun Gear	2	am-0040
CIM Sun Gear, 15t, 32dp	1	am-0556
10-32 x 5/8 SHCS w/ Nylon thread lock	2	am-1120
M3 x 10mm SHCS	4	am-1021
1/4-20 Nylock Nut	4	am-1015
1/4-20 x 2 SHCS	4	am-1012
1/2" E-clip	1	am-0206
10-32 x 5/8 SHCS w/ nylon thread lock patch	8	am-1120
Nylon Spacer	1	am-1151

3/16 Hex Head Driver (Allen Wrench)
7/16 Box End Wrench
Block of Wood
Small Mallet or Hammer

TB3 Box Assembly Instructions:

Step 1: Press FR6ZZ bearings into TB3 Motor Plate.

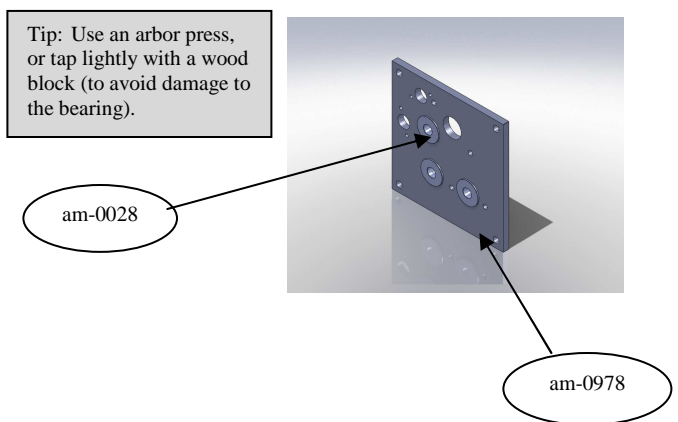

Step 2: Attach E-clip to the groove in the Output Shaft and insert Output Shaft, T-box Output Gear, and Nylon Spacer into bottom right bearing with the raised boss of the gear facing the bearing with the spacer in-between. Insert Small Hex Shafts into the other two bearings

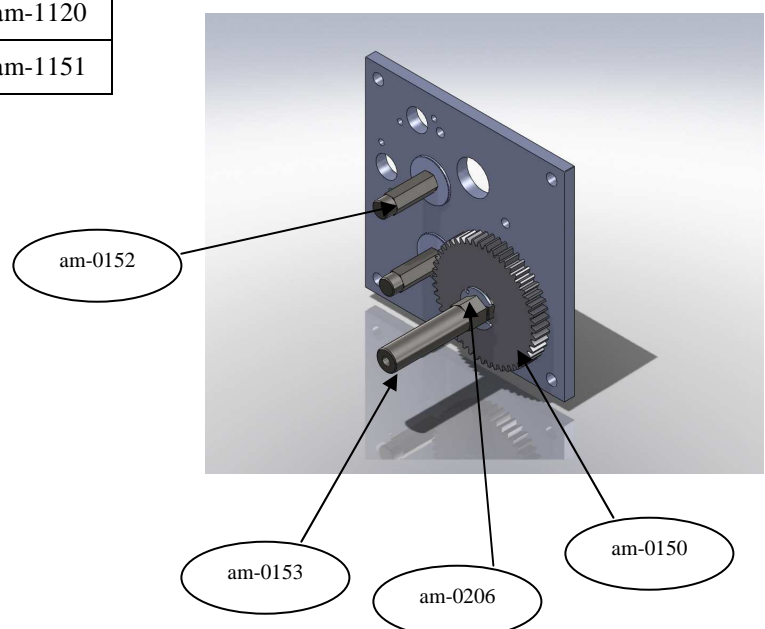

Step 3: Insert 14 Tooth Small Cluster Gear with the boss facing the bearing onto the Small Hex Shaft next to the Large Output Gear. Insert the 60 Tooth 32dp gear with the boss facing the bearing onto the other Small hex Shaft.

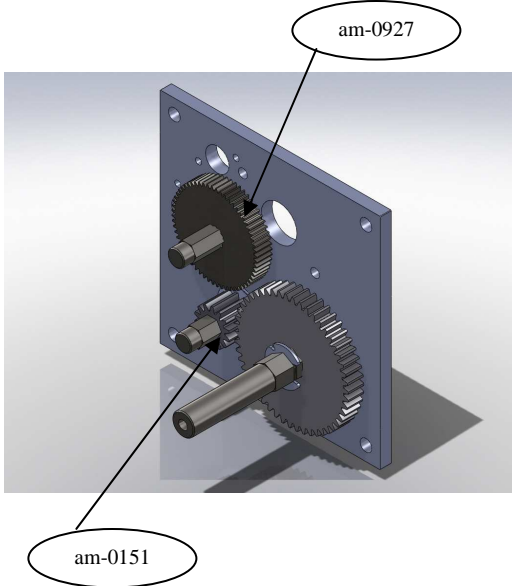

Step 4: Insert Small Cluster Gear onto the Small Hex Shaft with the 60 Tooth 32dp gear with the boss facing out. Insert the Large Cluster Gear onto the other Small Hex Shaft with the boss facing out.

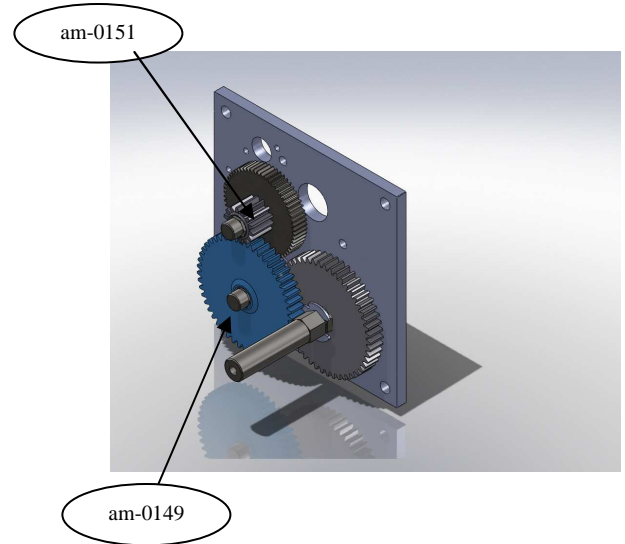

Step 5: Place the Toughbox Enclosure over the gear set.

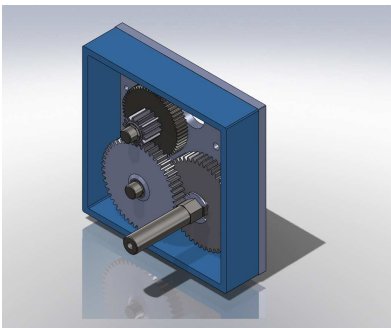

Step 6: Press the FR8ZZ and the two FR6ZZ bearings into the TB3 Shaft Plate with the flanges all on the same side.

Tip: Use wood block and mallet if needed.

Tip: Bearing flange goes on this side.

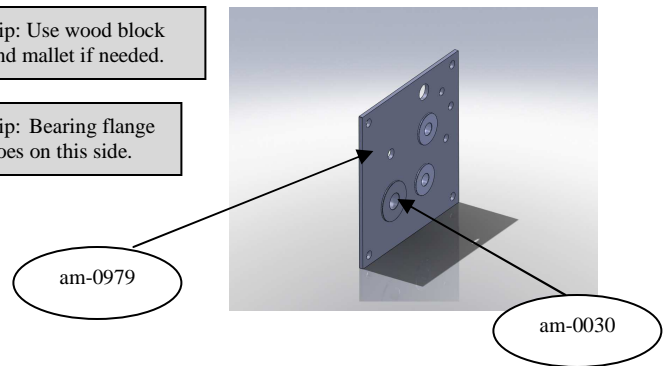

Step 7: Slide the TB3 Shaft Plate over the shafts with the bearing flange side facing the gears. Insert the 1/4-20 SHCS into the 4 exterior holes and secure with the 1/4-20 nuts.

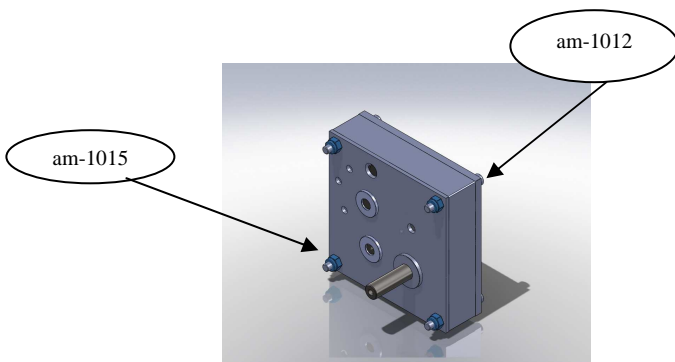

Step 8: To attach a CIM Motor slide the CIM Motor into the motor location near the middle of the TB3 Motor Plate. Use two 10-32 x 5/8" Screws to fasten the motor in place.

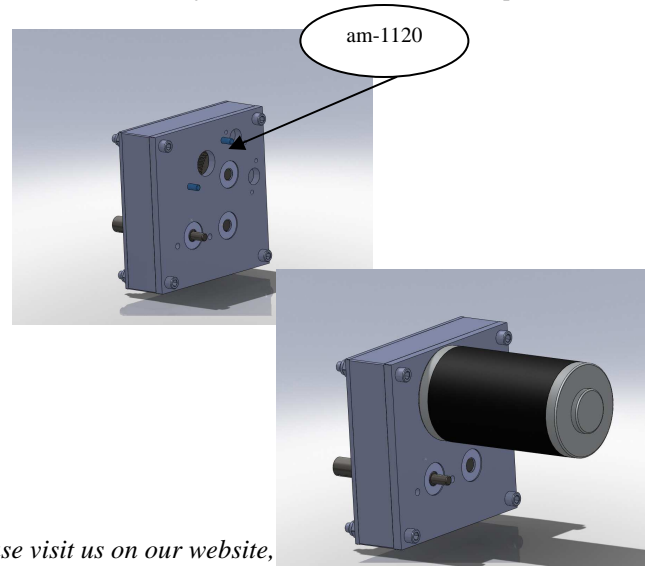

For more information on AndyMark products, please visit us on our website,

Step 9: To attach Fisher Price motors slide the Fisher Price Motors into the motor location holes on the top right side of the TB3 Motor Plate. Use two M3 x 10mm screws to fasten a motor in place.

