

REVISION HISTORY			
REV.	DESCRIPTION	DATE	DRAWN BY
1	ORIGINAL PRINT		A. BAKER
2	UPDATED TO AMDS-1	6/15/2018	A. MILLS

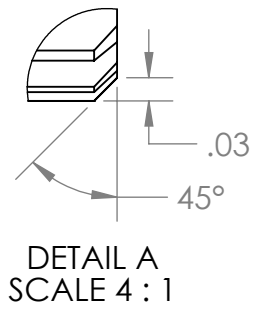

35T 20DP 14.5PA  
GEARSTOCK  
CLEAN CUT  
NO BURRS BETWEEN TEETH

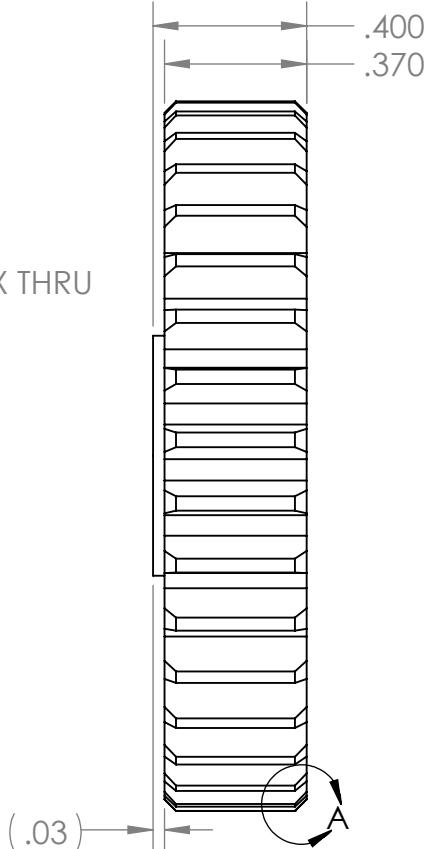
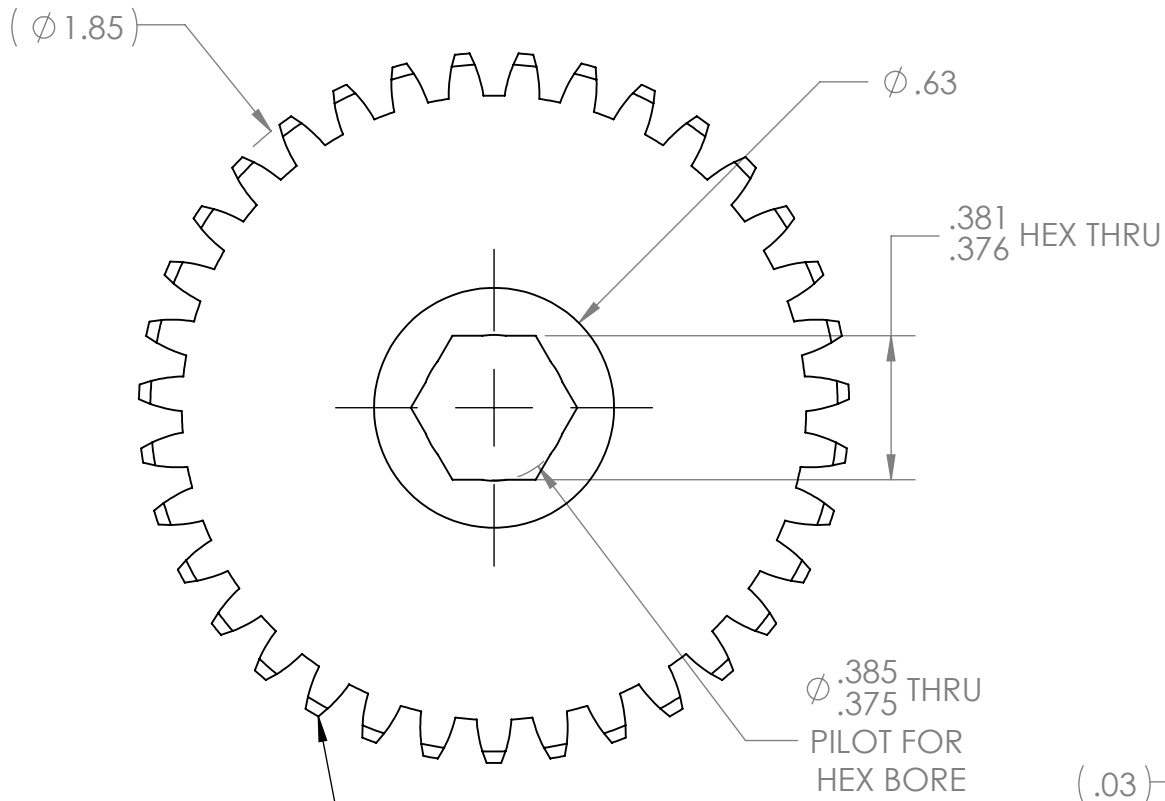
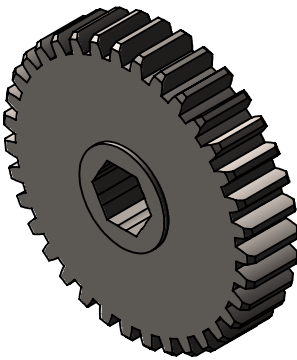

\*\*\* SEE CAD FOR ADDITIONAL TOOLPATH INFO\*\*\*

UNLESS OTHERWISE SPECIFIED:		COMMENTS:			
<b>DIMENSIONS ARE IN INCHES</b>		DUAL DIMENSIONS ARE IN MILLIMETERS.			
TOLERANCES:		BREAK ALL SHARP EDGES		TITLE:	
FRACTIONAL	±1/16			35T 20DP 14.5PA	
ANGULAR: MACH	±1°			375IN HEX BORE GEAR	
ANGULAR: BEND	±5°			SIZE	DWG. NO.
ONE PLACE DECIMAL	±0.1			<b>A</b>	am-0140
TWO PLACE DECIMAL	±0.01			SCALE: 2:1	WEIGHT:
THREE PLACE DECIMAL	±0.005			SHEET 1 OF 1	
FOUR PLACE DECIMAL	±0.0005				
MATERIAL		NAME	DATE	REV	
4140 STEEL		CHECKED	6/22/18	2	
FINISH		ENG APPR.			
ZINC PLATED		MFG APPR.			
DO NOT SCALE DRAWING		Q.A.			