

REVISION HISTORY			
REV.	DESCRIPTION	DATE	DRAWN BY
1	ORIGINAL PRINT	8/15/2012	A. BAKER
2	UPDATED TO AMDS-1	6/18/2018	A. MILLS

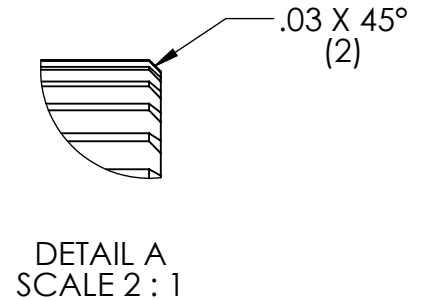

\*\*\* SEE CAD FOR ADDITIONAL TOOLPATH INFO\*\*\*

UNLESS OTHERWISE SPECIFIED:		COMMENTS:			
<b>DIMENSIONS ARE IN INCHES</b>		DUAL DIMENSIONS ARE IN MILLIMETERS.			
TOLERANCES:		BREAK ALL SHARP EDGES		TITLE:	
FRACTIONAL	$\pm 1/16$			50T 20DP 14.5PA	
ANGULAR: MACH	$\pm 1^\circ$			375 HEX GEAR	
ANGULAR: BEND	$\pm 5^\circ$			SIZE	DWG. NO.
ONE PLACE DECIMAL	$\pm 0.1$			<b>A</b>	am-0149
TWO PLACE DECIMAL	$\pm 0.01$			SCALE: 1:1	WEIGHT:
THREE PLACE DECIMAL	$\pm 0.005$			SHEET 1 OF 1	
FOUR PLACE DECIMAL	$\pm 0.0005$				
MATERIAL	4140 STEEL	NAME	DATE		
FINISH	ZINC PLATED	CHECKED	NL	6/6/2018	REV
DO NOT SCALE DRAWING		ENG APPR.			2
		MFG APPR.			
		Q.A.			

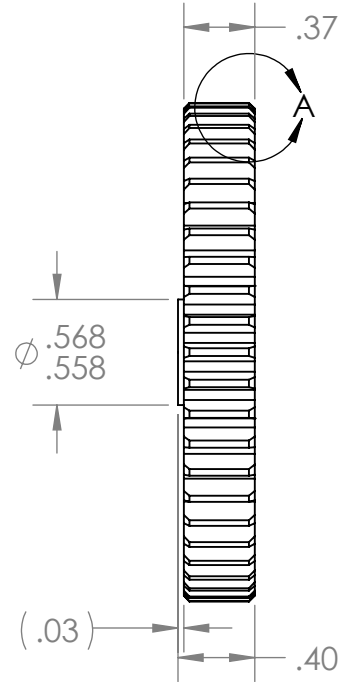
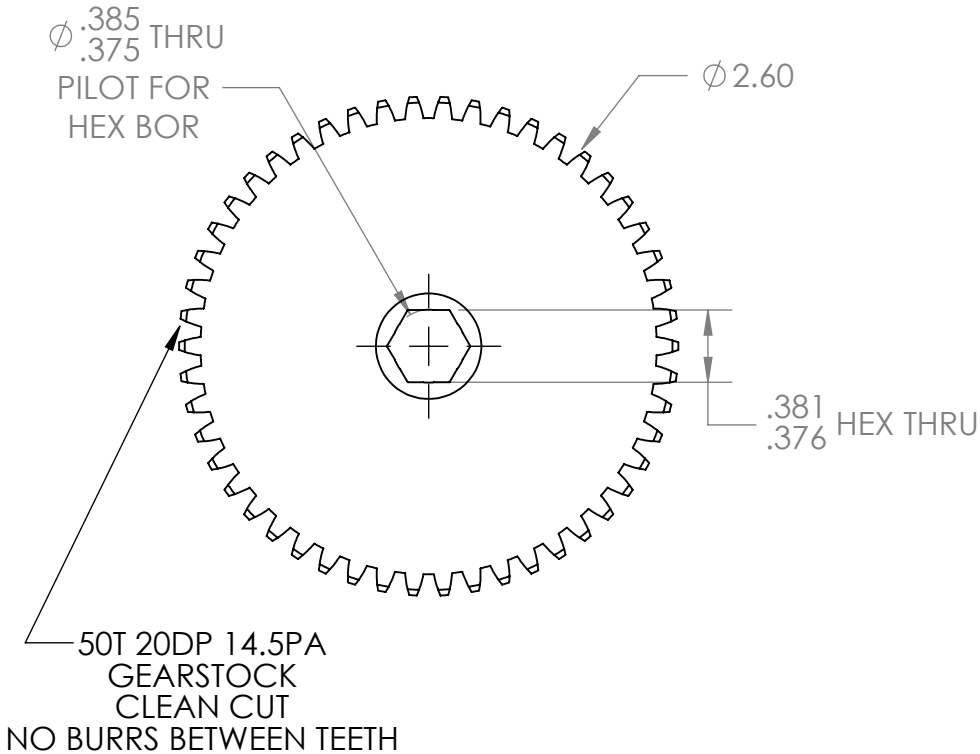