

4

3

2

1

REVISION HISTORY			
REV.	DESCRIPTION	DATE	DRAWN BY
1	ORIGINAL PRINT	10/9/2018	D. BLAU

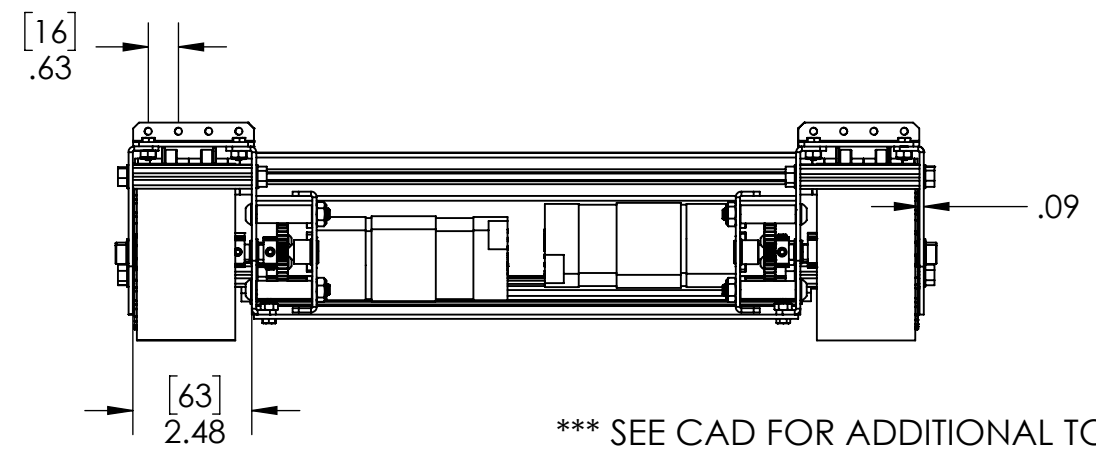
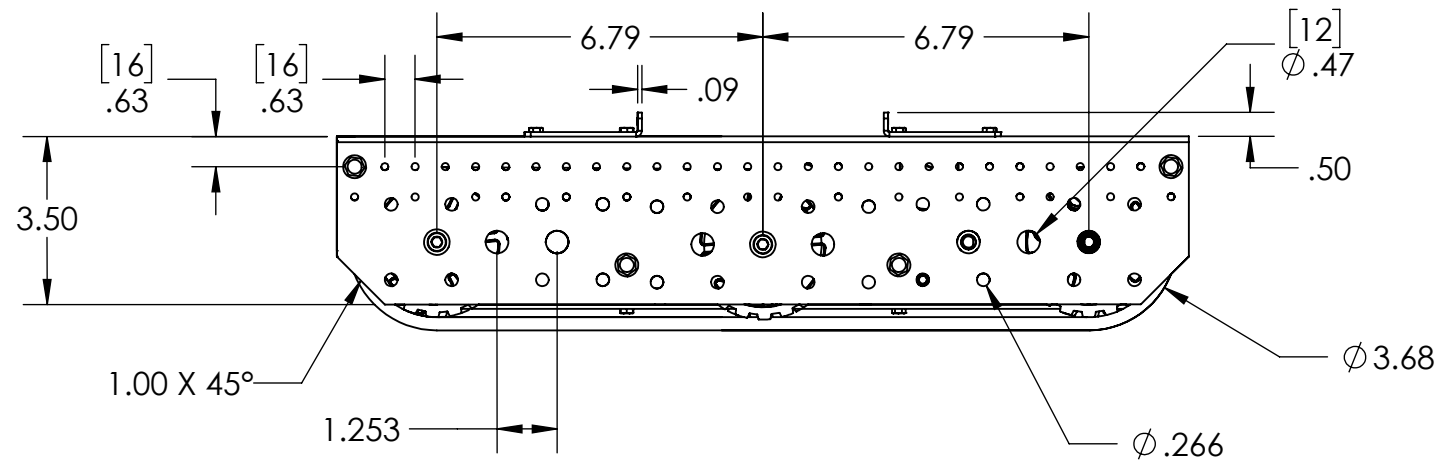
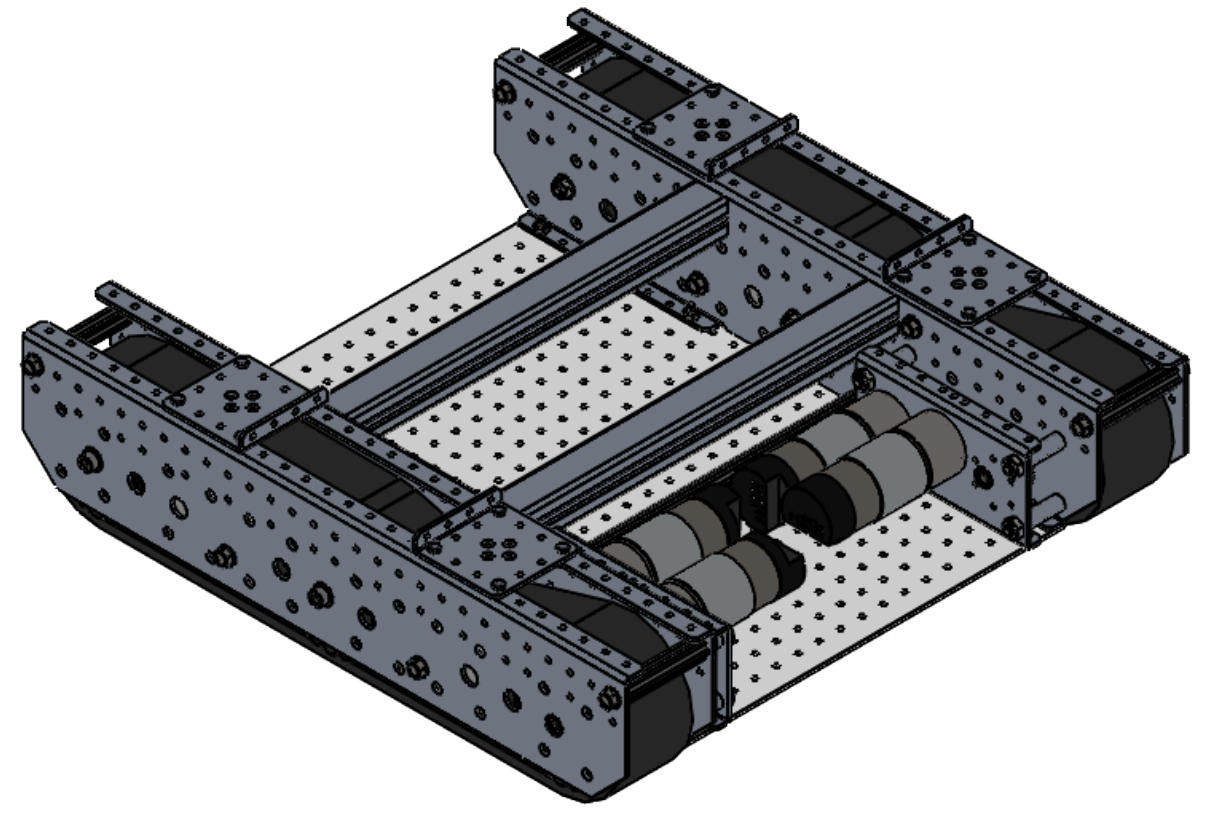
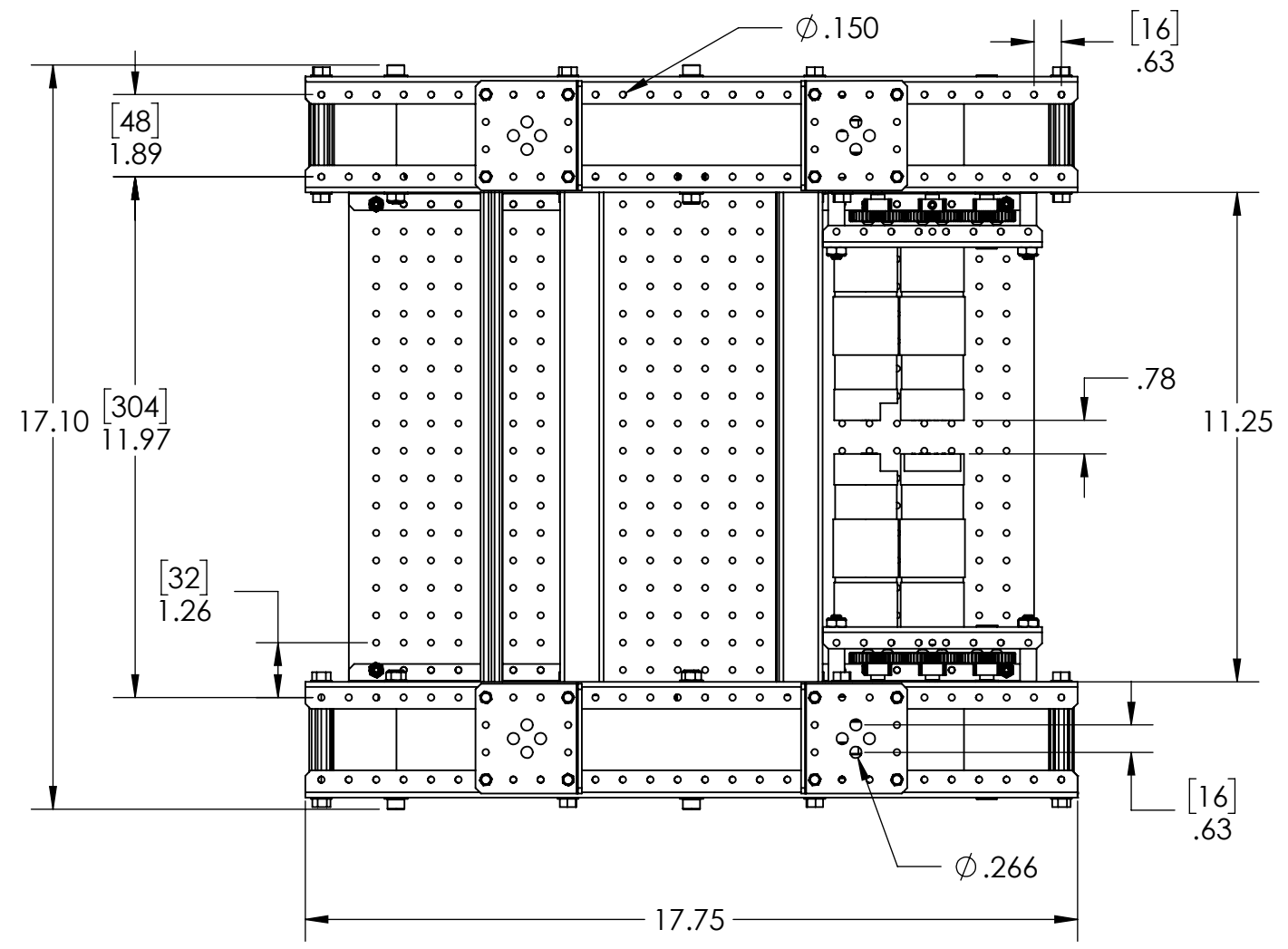

\*\*\* SEE CAD FOR ADDITIONAL TOOLPATH INFO\*\*\*

UNLESS OTHERWISE SPECIFIED:		COMMENTS:				
DIMENSIONS ARE IN INCHES		DUAL DIMENSIONS ARE IN MILLIMETERS.				
TOLERANCES:		BREAK ALL SHARP EDGES.		SIZE		
FRACTIONAL	±1/16			DWG. NO.		
ANGULAR: MACH	±1°			REV		
ANGULAR: BEND	±5°			1		
ONE PLACE DECIMAL	±0.1			SCALE: 1:4		
TWO PLACE DECIMAL	±0.01			SHEET 1 OF 1		
THREE PLACE DECIMAL	±0.005					
FOUR PLACE DECIMAL	±0.0005					
MATERIAL		CHECKED	NAME	DATE		
FINISH		ENG APPR.				
DO NOT SCALE DRAWING		MFG APPR.				
		Q.A.				

4

3

2

1

B

B

A

A