



**Step 2:** Mate the inside faces of the aluminum plates to the outside faces of the spacer. Make sure that the 12 holes in the spacer line up with the 12 holes in each of the plates.

The inside face of the plate should be clearly marked with either an "Inside Left" or "Inside Right" sticker.

Each left wheel is built with two left plates and each right wheel is built with two right plates. These instructions depict a left wheel, but the process holds true for both the left and right wheels.

**Step 3:** Put two of the 10-32 x 3.25" SHCS through the plates and hubs and tighten these down with a two of the 10-32 Nylock Jam nuts. This will hold the plates to the spacer as we begin to put the rollers on the wheel. We will refer to this part from now on as the **Plate/Spacer Sandwich!**

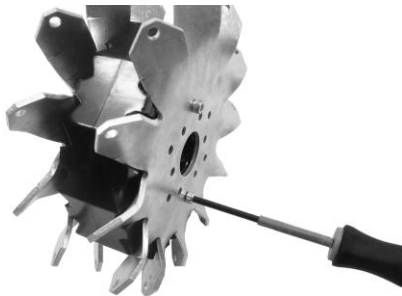

**Step 4:** Take another 10-32 x 3.25" SHCS and begin by putting a #10 washer (the smaller washer) on the screw.

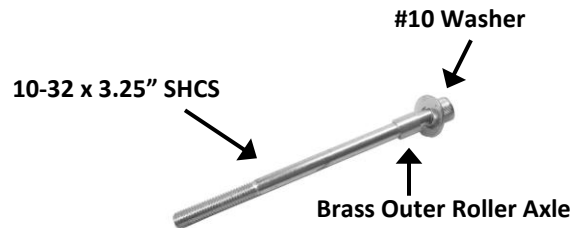

**Step 5:** Follow the #10 washer up with a Brass Outer Roller Axle (the smaller brass piece). See picture above.

**Step 6:** Add an 8" Mecanum Outer Roller to the screw assembly. The concave portion of the roller



should cover the head of the 10-32 x 3.25" SHCS.

**Step 7:** Put one of the Brass Inner Roller Axles inside one of the 8" Mecanum Inner Rollers.



**Step 8:** Take two of the ¼-20 Stainless Steel Washers and put them on the Brass Inner Roller Axles, one on each side of the 8" Mecanum Inner Roller.



**Step 9:** Set the Plate/Spacer Sandwich on end. With one hand, hold the Inner Roller, Inner Roller Brass Axle, and ¼-20 Stainless Steel washer in place between the tabs on each one of the Aluminum Plates.

While holding these parts in place, use your other hand slide the 10-32 x 3.25" SHCS that has the end roller on it through the aluminum plate on one side, through the Brass Inner Roller Axles, and through the plate on the other side.



**Step 10:** Slide the Brass Outer Roller Axle onto the threads of the 10-32 x 3.25" SHCS.



**Step 11:** Slide the Outer Roller over the Brass Outer Roller Axle.

**Step 12:** Put a #10 washer on the end of the 10-32 x 3.25" SHCS.



**Step 13:** Put a 10-32 Nylock Jam Nut on the end of the 10-32 x 3.25" SHCS to finish off the roller assembly. Be sure to tighten the screw enough that the rollers are spinning on the brass axles and the brass axles are **NOT** spinning on the screw. The

rollers may seem to not spin free enough at first, but these will loosen up as the wheels get used.

**Important Note:** When tightening the roller assembly, make sure that the ¼-20 Stainless Steel washers have not fallen between the Brass Inner Roller Axles and the Aluminum Plate. See the cross section below for reference:

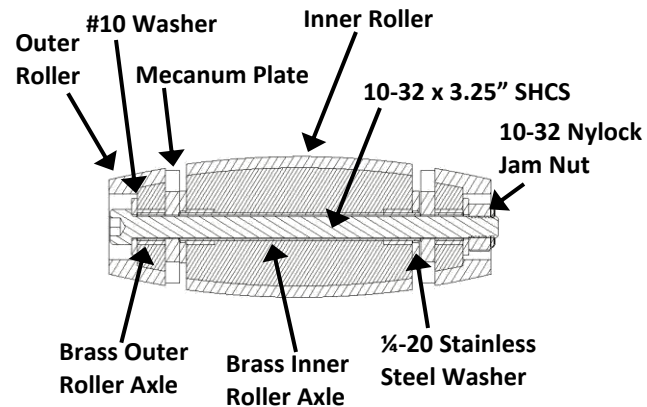

**Step 14:** Continue assembling the rollers by repeating Steps 4 through 13.

**Step 15:** After all the rollers are completely attached, remove the two screws you were using to hold the Plate/Spacer Sandwich together and add in either a hub or the sprocket you will use to drive the wheel using the 6 remaining 10-32 x 3.25" SHCS and 10-32 Jam Nuts. If you are using a sprocket, you will need to use a 250 and a 550 sprocket spacer to clear the outer rollers.

For more information visit our website:  
[www.andymark.com](http://www.andymark.com)

## 8" Mecanum HD Wheel User Guide and Assembly Instructions

A Product Of:



### Bill of Materials

- 2 – Aluminum Plates (2 Lefts or 2 Rights)
- 1 – 8" Mecanum Support Spacer (2 halves)
- 12 – 8" Mecanum Inner Roller
- 12 – Brass Inner Roller Axles
- 18 – 10-32 x 3.25" SHCS
- 18 – 10-32 Nylock Jam Nuts
- 24 – ¼-20 Stainless Steel Washers
- 24 – 8" Mecanum Outer Roller
- 24 – Brass Outer Roller Axles
- 24 – #10 Washers

### Tools Needed

- 1 – 5/32" Hex Driver (Allen Wrench)
- 1 – 3/8" Wrench or Socket Driver

### Assembly Instructions

**Step 1:** Mate the two halves of the 8 Inch Mecanum Support Spacer together. There are locating studs on the inside of the molded plastic piece to help get the two halves into the correct position.

