

10-32 Tapped Hole (2)

PROPRIETARY AND CONFIDENTIAL
 THE INFORMATION CONTAINED IN THIS DRAWING IS THE SOLE PROPERTY OF <INSERT COMPANY NAME HERE>. ANY REPRODUCTION IN PART OR AS A WHOLE WITHOUT THE WRITTEN PERMISSION OF <INSERT COMPANY NAME HERE> IS PROHIBITED.

		UNLESS OTHERWISE SPECIFIED:		NAME	DATE
		DIMENSIONS ARE IN INCHES	DRAWN	MK	11-16-12
		TOLERANCES:	CHECKED		
		FRACTIONAL ±	ENG APPR.		
		ANGULAR: MACH ± BEND ±	MFG APPR.		
		TWO PLACE DECIMAL ±	Q.A.		
		THREE PLACE DECIMAL ±	COMMENTS:		
		INTERPRET GEOMETRIC TOLERANCING PER:			
		MATERIAL			
		5052 Aluminum			
		FINISH			
		Deburred			
NEXT ASSY	USED ON				
APPLICATION		DO NOT SCALE DRAWING			

AndyMark Inc.		
TITLE:		
RAW Gearbox Side Plate		
SIZE	DWG. NO.	REV
A	AM-2358	2
SCALE: 1:1	WEIGHT:	SHEET 3 OF 13

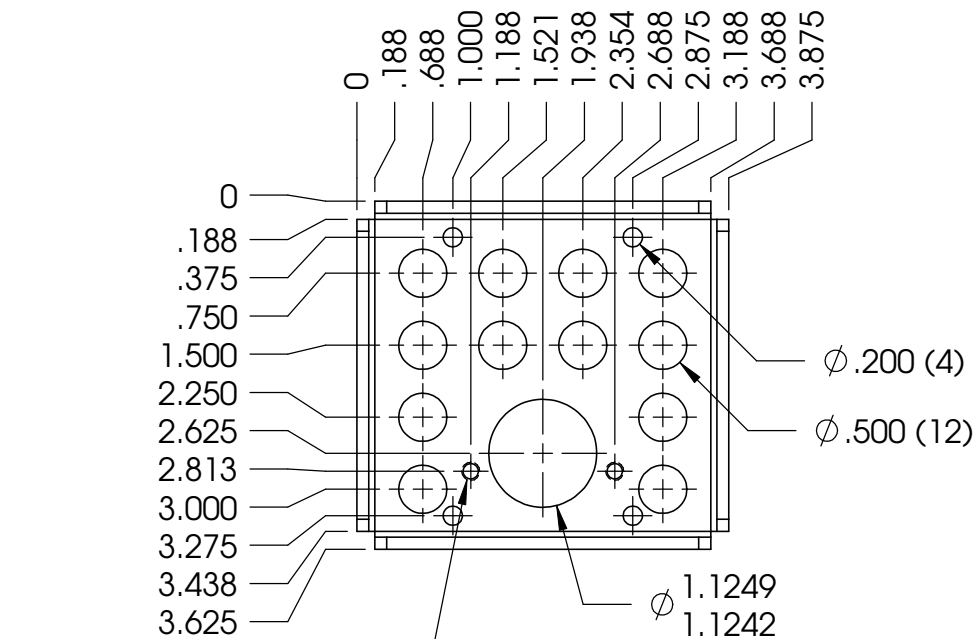

10-32 Tapped Hole (2)

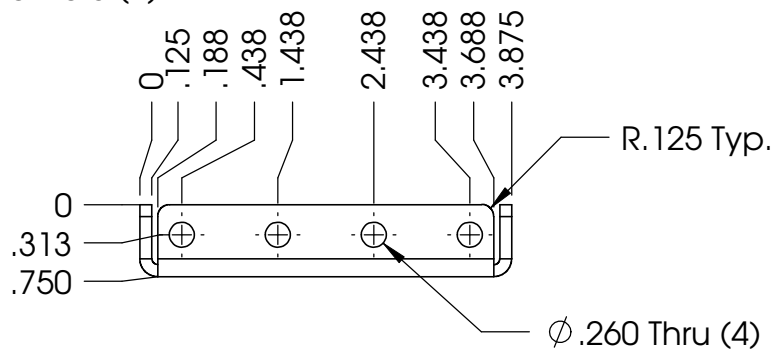
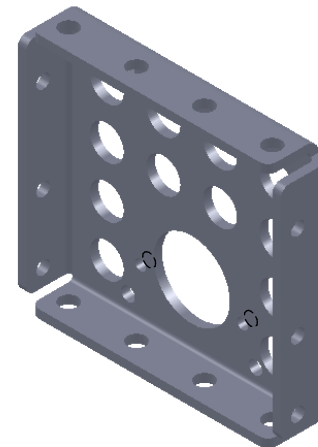
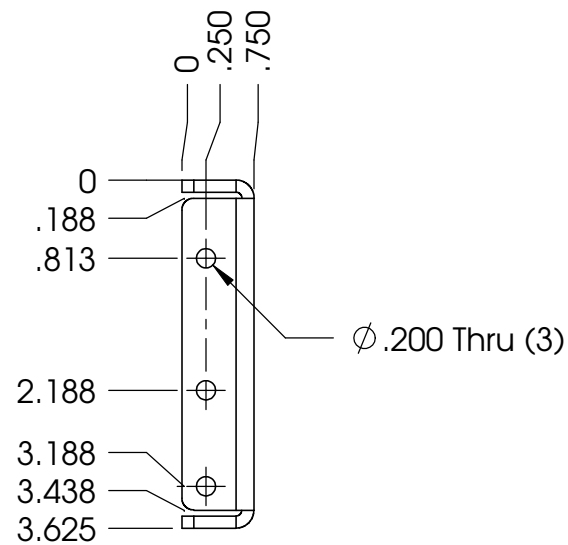

PROPRIETARY AND CONFIDENTIAL
 THE INFORMATION CONTAINED IN THIS DRAWING IS THE SOLE PROPERTY OF <INSERT COMPANY NAME HERE>. ANY REPRODUCTION IN PART OR AS A WHOLE WITHOUT THE WRITTEN PERMISSION OF <INSERT COMPANY NAME HERE> IS PROHIBITED.

		UNLESS OTHERWISE SPECIFIED:		NAME	DATE
		DIMENSIONS ARE IN INCHES	DRAWN	MK	11-16-12
		TOLERANCES:	CHECKED		
		FRACTIONAL \pm	ENG APPR.		
		ANGULAR: MACH \pm BEND \pm	MFG APPR.		
		TWO PLACE DECIMAL $\pm .01$	Q.A.		
		THREE PLACE DECIMAL $\pm .005$	COMMENTS:		
		INTERPRET GEOMETRIC TOLERANCING PER:			
		MATERIAL			
		5052 Aluminum			
		FINISH			
		Deburred			
NEXT ASSY	USED ON				
APPLICATION		DO NOT SCALE DRAWING			

AndyMark Inc.		
TITLE: RAW Gearbox Side Plate		
SIZE A	DWG. NO. AM-2358	REV 2
SCALE: 1:1	WEIGHT:	SHEET 4 OF 13

5

4

3

2

1