

.084
.079 FOR 2mm KEY

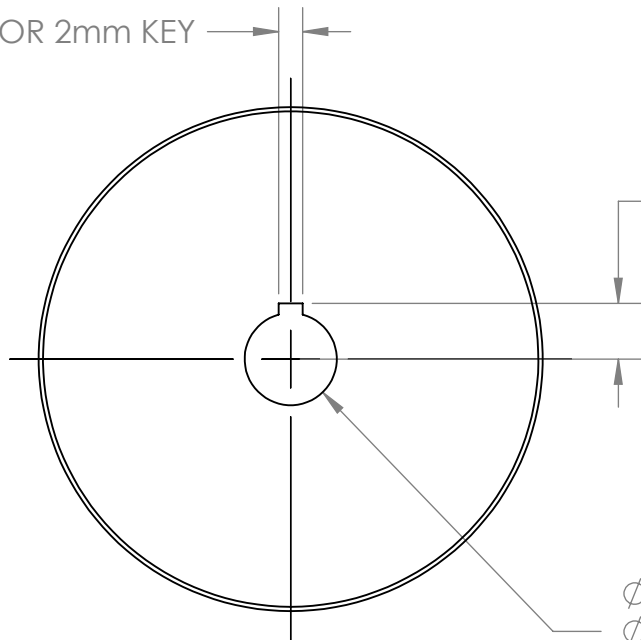

.194
.189

Ø .319
Ø .314
BORE

.015 x 45°
CHAMFER

.345

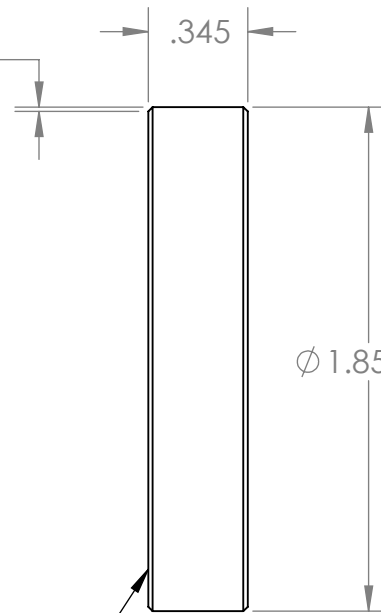

Ø 1.85 OD

CLEAN CUT REQUIRED
SO NO BURRS REMAIN
BETWEEN GEAR TEETH

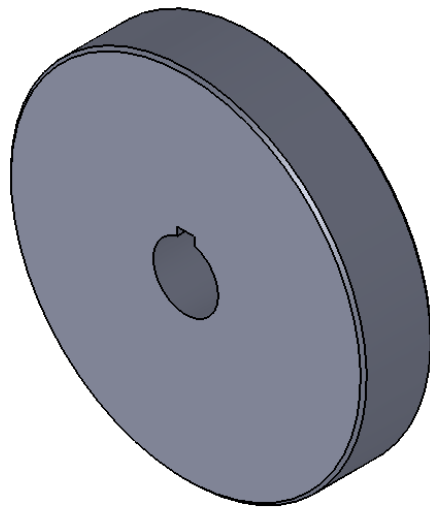

UNLESS OTHERWISE SPECIFIED:		NAME	DATE	AndyMark Inc.		
DIMENSIONS ARE IN INCHES		DRAWN				TITLE:
TOLERANCES:		CHECKED		35T 20dp 313k		
FRACTIONAL ±		ENG APPR.				
ANGULAR: MACH ± BEND ±		MFG APPR.		SIZE	DWG. NO.	REV
TWO PLACE DECIMAL ±		Q.A.		A	am-2460	1
THREE PLACE DECIMAL ±		COMMENTS:		SCALE: 1:1	WEIGHT:	SHEET 1 OF 1
INTERPRET GEOMETRIC TOLERANCING PER:						
MATERIAL						
FINISH						
DO NOT SCALE DRAWING						