

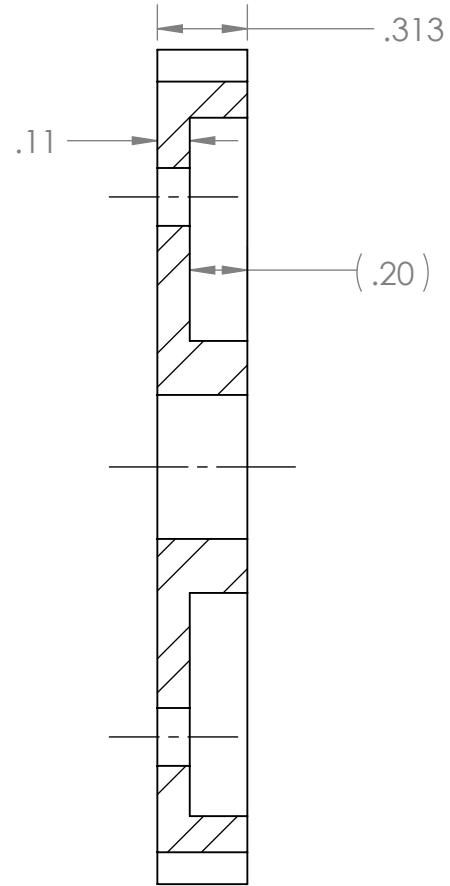

REVISION HISTORY			
REV.	DESCRIPTION	DATE	DRAWN BY
1	ORIGINAL PRINT	9/5/2017	N. MASSOUDA

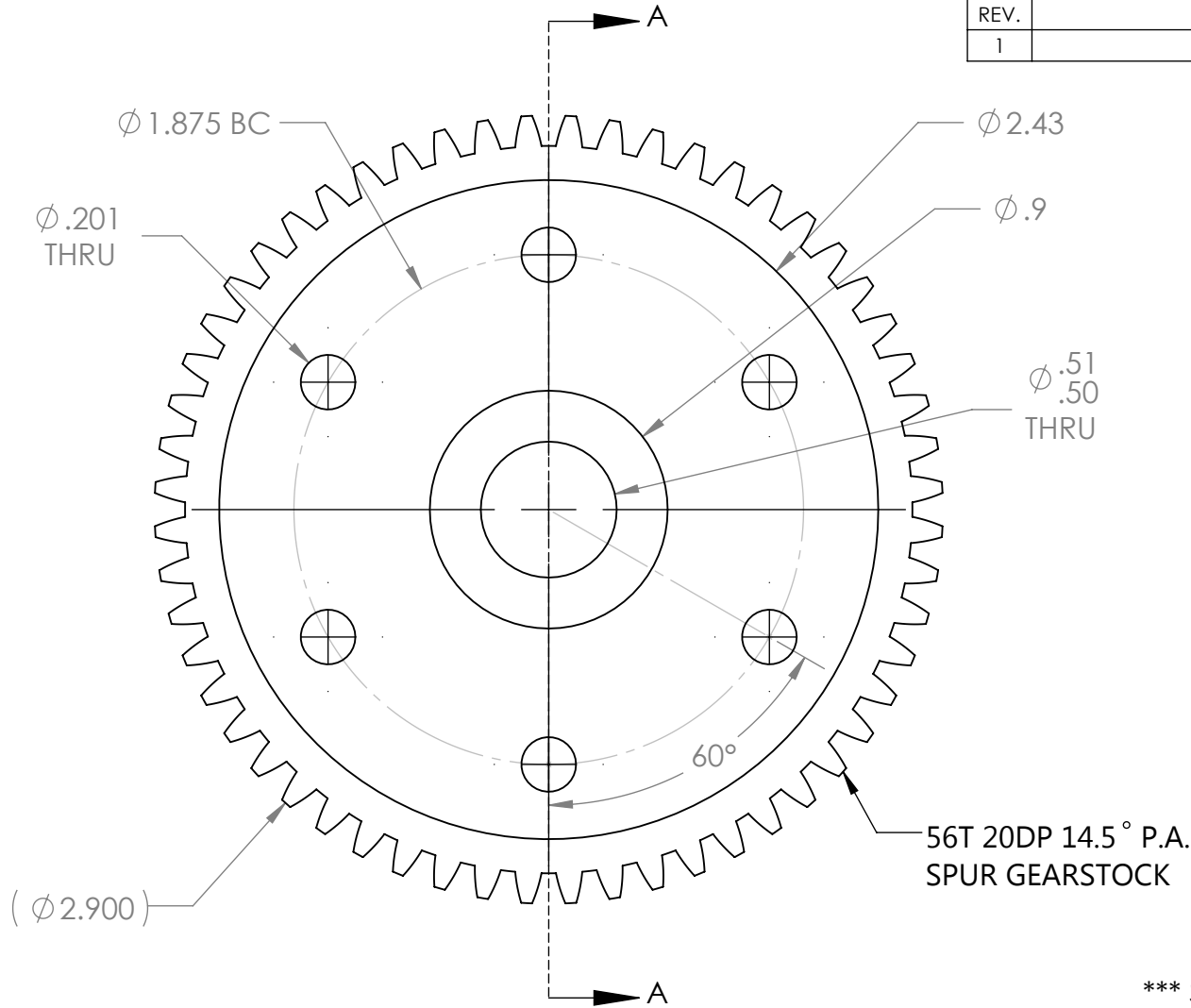

SECTION A-A

*** SEE CAD FOR ADDITIONAL TOOLPATH INFO***

UNLESS OTHERWISE SPECIFIED:		COMMENTS:				
DIMENSIONS ARE IN INCHES		DUAL DIMENSIONS ARE IN MILLIMETERS.				
TOLERANCES:		BREAK ALL SHARP EDGES.		TITLE:		
FRACTIONAL	$\pm 1/16$			56T 20DP 0.5 BORE		
ANGULAR: MACH	$\pm 1^\circ$			1.875BC GEAR		
ANGULAR: BEND	$\pm 5^\circ$			SIZE	DWG. NO.	REV
ONE PLACE DECIMAL	± 0.1			A	am-3712	1
TWO PLACE DECIMAL	± 0.01			SCALE: 3:2		
THREE PLACE DECIMAL	± 0.005			SHEET 1 OF 1		
FOUR PLACE DECIMAL	± 0.0005					
MATERIAL	4140 STEEL	CHECKED	NAME	DATE		
FINISH	ZINC PLATED	ENG APPR.				
DO NOT SCALE DRAWING		MFG APPR.				
		Q.A.				