

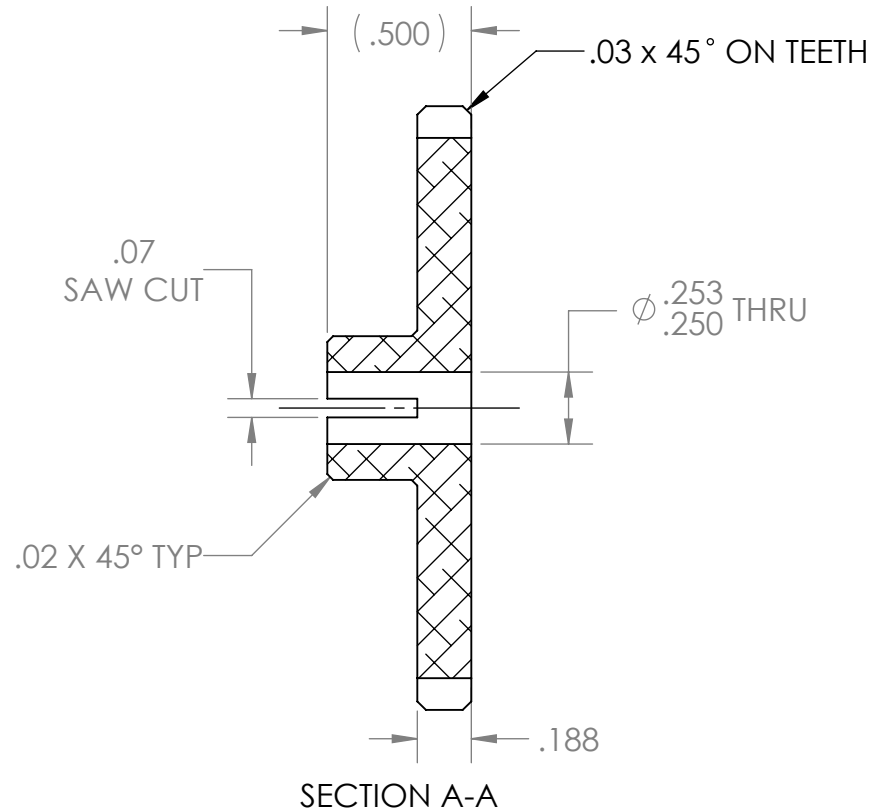

REVISION HISTORY			
REV.	DESCRIPTION	DATE	DRAWN BY
1	ORIGINAL PRINT	11/13/2015	N. LAWRENCE
2	REDRAWN TO AMDS-1	7/23/2018	N. LAWRENCE

40T 20DP 14.5° P.A°
CLEAN CUT GEAR TEETH
NO BURRS

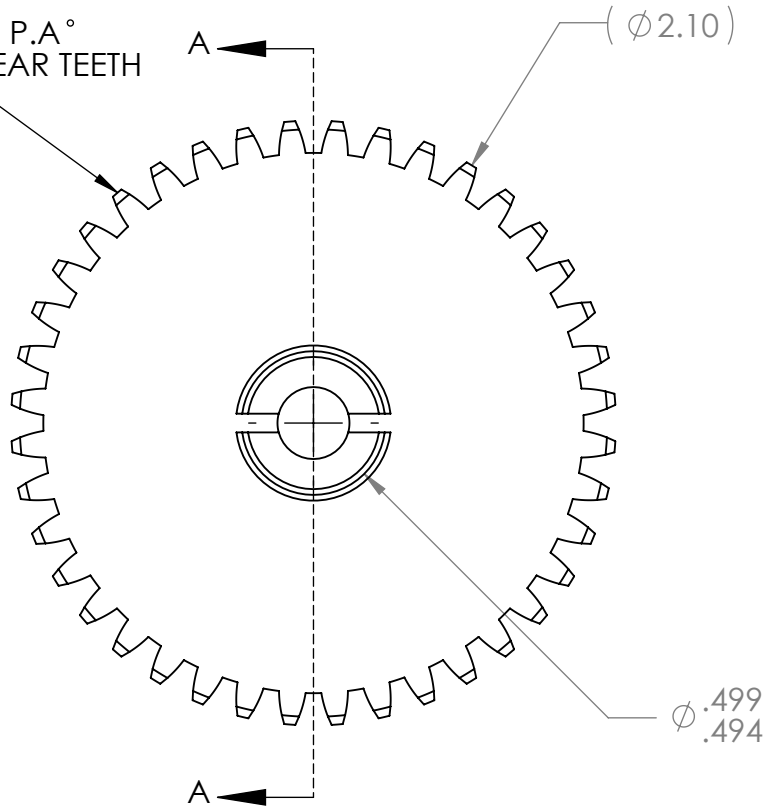
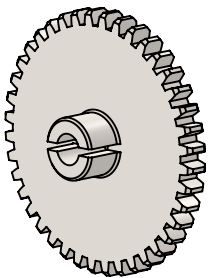

*** SEE CAD FOR ADDITIONAL TOOLPATH INFO***



UNLESS OTHERWISE SPECIFIED:		COMMENTS:				
DIMENSIONS ARE IN INCHES		DUAL DIMENSIONS ARE IN MILLIMETERS.				
TOLERANCES:		BREAK ALL SHARP EDGES.		TITLE:		
FRACTIONAL	±1/16			40T 20DP 14.5PA		
ANGULAR: MACH	±1°			250IN ENCODER GEAR		
ANGULAR: BEND	±5°					
ONE PLACE DECIMAL	±0.1					
TWO PLACE DECIMAL	±0.01					
THREE PLACE DECIMAL	±0.005					
FOUR PLACE DECIMAL	±0.0005					
MATERIAL	6061 AL	CHECKED	NAME	DATE	SIZE	DWG. NO.
FINISH	DEBURRED	ENG APPR.			A	am-3308
DO NOT SCALE DRAWING		MFG APPR.			SCALE: 1.5:1	
		Q.A.			SHEET 1 OF 1	
						REV
						2