

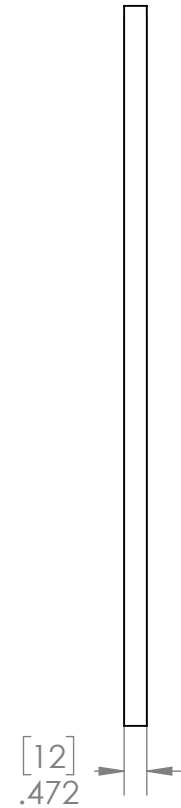

REVISION HISTORY			
REV.	DESCRIPTION	DATE	DRAWN BY
1	ORIGINAL PRINT	2/19/2021	N. LAWRENCE
2	DECREASED THRU HOLE DIAMETER	3/26/2021	N. LAWRENCE
3	INCREASED HOLE DIAMETER, CHANGED TO AM PART #	4/19/2021	N. LAWRENCE

[49.13]
 ϕ 1.934
 BOLT CIRCLE
 CONCENTRIC TO
 OUTER EDGE

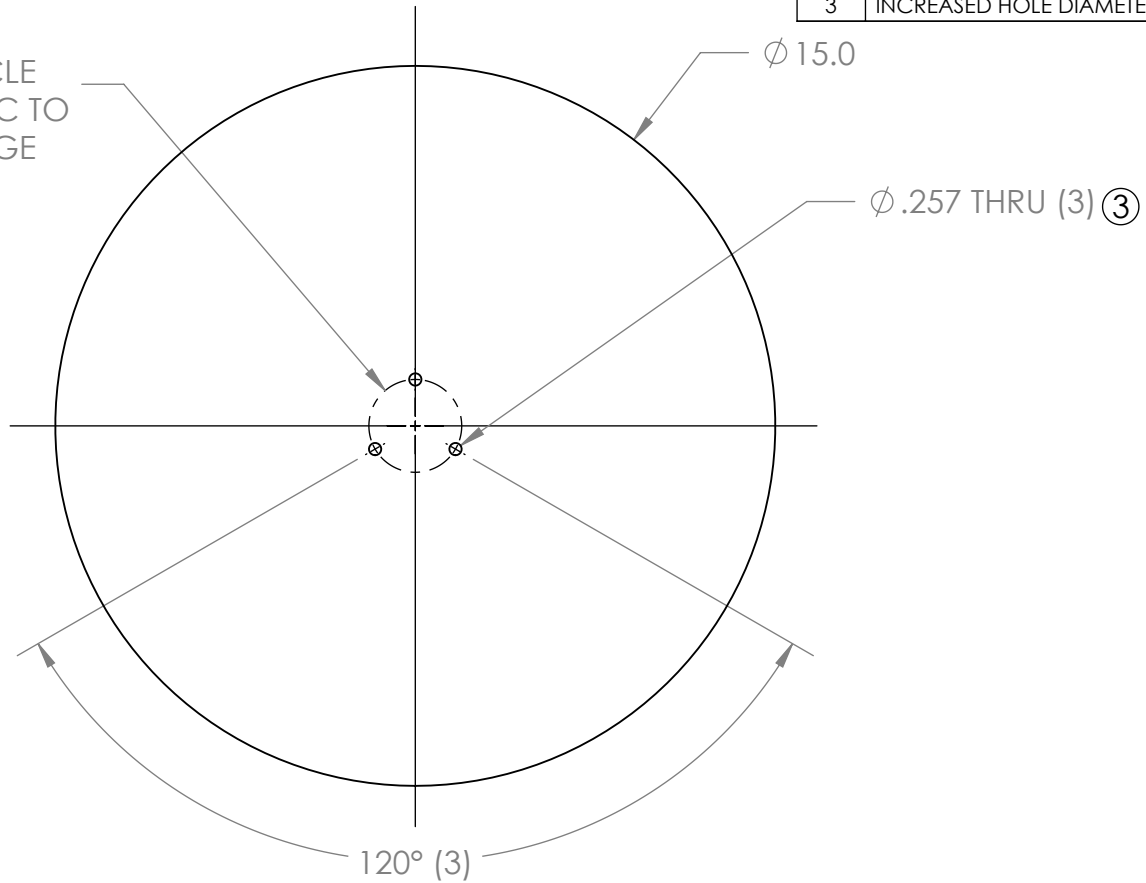
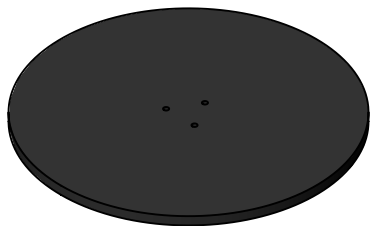

*** SEE CAD FOR ADDITIONAL TOOLPATH INFO***



UNLESS OTHERWISE SPECIFIED:		COMMENTS:			
DIMENSIONS ARE IN INCHES		DUAL DIMENSIONS ARE IN MILLIMETERS.			
TOLERANCES:		BREAK ALL SHARP EDGES.		TITLE:	
FRACTIONAL	$\pm 1/16$			CAROUSEL TOP	
ANGULAR: MACH	$\pm 1^\circ$				
ANGULAR: BEND	$\pm 5^\circ$				
ONE PLACE DECIMAL	± 0.1				
TWO PLACE DECIMAL	± 0.01	MATERIAL		SIZE	DWG. NO.
THREE PLACE DECIMAL	± 0.005	BLACK PVC FOAM		A	am-4497
FOUR PLACE DECIMAL	± 0.0005	FINISH		SCALE: 1:4	SHEET 1 OF 1
DO NOT SCALE DRAWING		Q.A.			

5

4

3

2

1